

The Machlett Laboratories, Inc. • 1063 Hope Street
 Stamford, Conn. 06907 • Tel. 203-348-7511 • TWX 203-327-2496

ML 66967A

ISSUED 9-67

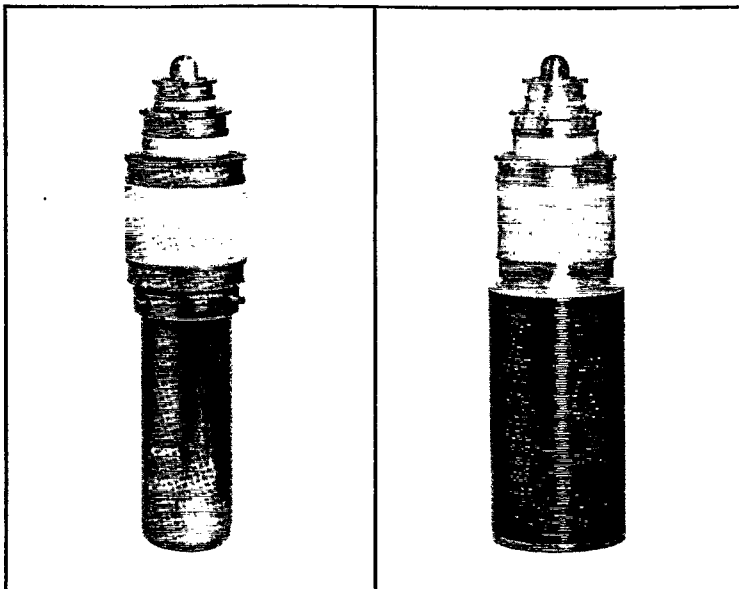

ML-6696A
 ML-6697A

General Purpose Triodes
 80 kW CW



DESCRIPTION

The ML-6696A and ML-6697A are general-purpose triodes suitable for industrial heating and AM broadcasting. These tubes feature rugged coaxial mounting structures providing high-dissipation, low-inductance rf electrode terminals. The envelopes employ strong, low-loss ceramic insulation. The cathode of each type consists of sturdy, self-supporting, stress-free, thoriated-tungsten filaments.

The ML-6696A has a water-cooled, heavy-wall anode capa-

ble of dissipating 60 kW. The ML-6697A has a forced air-cooled, heavy-wall anode with high-efficiency disc fins capable of dissipating 35 kW.

These tubes will operate with plate voltages up to 16 kV in CW operation. Maximum ratings apply at frequencies up to 40 MHz. Useful power output can be obtained at frequencies up to 80 MHz with reduced ratings.

GENERAL CHARACTERISTICS

Electrical

Filament Voltage	13.0	Volts
Filament Current	205	Amps
Filament Starting Current, maximum	800	Amps
Filament Cold Resistance	0.0073	Ohm
Amplification Factor	20	
Interelectrode Capacitances		
Grid-Plate	55	pf
Grid-Filament	76	pf
Plate-Filament	2.7	pf

Mechanical

Mounting Position	Vertical, anode down
Type of Cooling — ML-6696A	Water and forced-air†
Water flow on anode for 60 kW dissipation, approx.	18 gpm
Maximum outgoing water temperature	70 °C
Type of Cooling — ML 6697A	Forced-air
Air flow on anode for 35 kW dissipation	Pressure: 1700 cfm at 7.8" water*
Maximum incoming air temperature	Exhaust: 1970 cfm at 8.4" water*
Maximum Envelope Temperature	50 °C
Net Weight, approximate	200 °C†
ML-6696A	17 lbs.
ML 6697A	43 lbs.

*When used with ML-6697A air distributor F-17759.

†Auxiliary air flow of 50-100 cfm is required and should be distributed to maintain a uniform ceramic temperature, not greater than 200°C, around the circumference of the seals. At high frequencies or high ambient temperature, additional air flow may be required.

MAXIMUM RATINGS AND TYPICAL OPERATING CONDITIONS

(Continuous Commercial Service)

VALUES APPLY TO BOTH TYPES UNLESS OTHERWISE SPECIFIED

Audio-Frequency Power Amplifier and Modulator Class B

Maximum Ratings, Absolute Values

D-C Plate Voltage	16000	volts
Max.-Signal D-C Plate Current*	11	amps
Max.-Signal Plate Input*		
ML-6696A	120	kW
ML-6697A	110	kW
Plate Dissipation		
ML-6696A	60	kW
ML-6697A	35	kW

Typical Operation (Values are for two tubes) **ML-6696A**

D-C Plate Voltage	10000	12000	volts
D-C Grid Voltage	-450	-600	volts
Peak A-F Grid-to-Grid Voltage	1750	2120	volts
Peak A-F Plate-to-Plate Voltage	16000	19200	volts
Zero Signal D-C Plate Current	3.0	2.0	amps
Max.-Signal D-C Plate Current	17.4	20.0	amps
Effective Load Resistance, Plate-to-Plate ..	1170	1230	ohms
Max.-Signal Driving Power, approx.	550	600	watts
Max.-Signal Power Output, approx.	110	152	kW

*Average over any audio-frequency cycle of sine-wave form.

Radio Frequency Power Amplifier Class B

Carrier conditions per tube for use with a maximum modulation factor of 1.0.

Maximum Ratings, Absolute Values

D-C Plate Voltage	16000	volts
D-C Plate Current	9	amps
Plate Input		
ML-6696A	90	kW
ML-6697A	55	kW

Plate Dissipation

ML-6696A	60	kW
ML-6697A	35	kW

Typical Operation **ML-6696A**

D-C Plate Voltage	12000	12000	volts
D-C Grid Voltage	-550	-550	volts
Peak R-F Grid Voltage	510	640	volts
Peak R-F Plate Voltage	5300	5300	volts
D-C Plate Current	4.3	6.8	amps
D-C Grid Current	0	0	mA
R-F Load Resistance	780	500	ohms
Driving Power, approx.†	450	1500	watts
Power Output, approx.	18	28	kW

†At crest of audio-frequency cycle with modulation factor of 1.0.

Plate-Modulated R-F Power Amplifier Class C Telephony

Carrier conditions per tube for use with a maximum modulation factor of 1.0.

Maximum Ratings, Absolute Values

D-C Plate Voltage	10000	volts
D-C Grid Voltage	-3200	volts
D-C Plate Current	8.5	amps
D-C Grid Current	2.0	amps
Plate Input	81	kW
Plate Dissipation		
ML-6696A	40	kW
ML-6697A	23	kW

Typical Operation

D-C Plate Voltage	9500	volts
D-C Grid Voltage	-1600	volts
Peak R-F Grid Voltage	2300	volts
Peak R-F Plate Voltage	7800	volts
D-C Plate Current	8.4	amps
D-C Grid Current	0.90	amp
R-F Load Resistance	510	ohms
Driving Power, approx.	2.0	kW
Power Output, approx.	60	kW

R-F Power Amplifier and Oscillator Class C Telegraphy

Key-down conditions per tube without amplitude modulation‡

Maximum Ratings, Absolute Values

D-C Plate Voltage	16000	volts
D-C Grid Voltage	-3200	volts
D-C Plate Current	11	amps
D-C Grid Current	2.0	amps
Plate Input	120	kW

Plate Dissipation

ML-6696A	60	kW
ML-6697A	35	kW

Typical Operation

D-C Plate Voltage	10000	15000	volts
D-C Grid Voltage	-1200	-1600	volts
Peak R-F Grid Voltage	1900	2120	volts
Peak R-F Plate Voltage	8000	12500	volts
D-C Plate Current	10.0	7.0	amps
D-C Grid Current	0.81	0.30	amp
R-F Load Resistance	440	970	ohms
Driving Power, approx.	1.5	0.60	kW
Power Output, approx.	72	80	kW

‡Modulation essentially negative may be used if the positive peak of the envelope does not exceed 115% of carrier conditions.

CHARACTERISTIC RANGE VALUES FOR EQUIPMENT DESIGN

Characteristics	Conditions	Limits		
		Minimum	Bogey	Maximum
Grid Voltage	$e_b = 1500$ volts; $i_b = 48$ amps	e_c : —	—	1000 volts
Grid Current	$e_b = 1500$ volts; $i_b = 48$ amps	i_c : —	—	15 amps
Plate Voltage	$E_c = 0$ Vdc; $I_b = 3.0$ Adc	E_b : 1.9	2.4	2.9 kVdc
Plate Voltage	$E_c = -200$ Vdc; $I_b = 3.0$ Adc	E_b : 5.6	6.4	7.2 kVdc
Grid Voltage	$E_b = 15.0$ kVdc; $I_b = 0.020$ Adc	E_c : -700	-820	-940 Vdc
Plate Power Output	$E_b = 15.0$ kVdc; $I_b = 7.0$ Adc; $E_c = -1600$ Vdc; $I_c = 0.30$ Adc	P_o : 68	—	— kW

MAXIMUM FREQUENCY RATINGS

Maximum ratings apply up to 40 MHz except as noted. The tube may be operated at higher frequencies provided the maximum values of plate voltage and power input are reduced according to the tabulation on the right. (Other maximum ratings are the same as shown above.) Special attention should be given to adequate ventilation of the bulb at the higher frequencies.

Frequency	40	60	80 MHz
Percent Maximum Rated Plate Voltage and Plate Input			
Class B	100	80	55
Class C	100	75	50

APPLICATION NOTES

Introduction

These tubes, as all high-power vacuum tubes, require some aging when they are first used in any new equipment or new environment. As the system power level increases, particularly if attended by a decrease in impedance level, it becomes increasingly important to spend enough time to acclimate the tube to the desired conditions of operation. *There is no substitute for seasoning the tube in the actual equipment in which it is to operate.* Once the procedure has been followed, however, the tube generally will be available for substantially immediate operation, unless it has been idle for an extended period of time, say three months or more.

Aging Procedure

The aging schedule will vary with the particular operating and environmental conditions. A general procedure which will serve as a starting point is to operate the tube for approximately one-half hour at each of the following steps:

- (a) filament voltage only;
- (b) partial plate voltage, drive and load, up to about one-half normal;
- (c) full plate voltage, drive and load.

The length of time necessary for break-in to insure reliable operation can vary widely. Only experience will tell whether the above procedure can be shortened, or whether steps (b) and (c) must be extended, perhaps by a factor of two or three. The major factors affecting break-in time are the *method of applying plate voltage*, the type of *protective circuitry* available to remove power in the event of a fault, and, for a spare tube, the length of time since it had been removed from normal operation.

Plate voltage is applied preferably by continuous or stepped control. Snap-on of full plate voltage with no load may develop excessive transients which cause breakdown in the tube or other circuit components. If the voltage must be snapped on at full value, at least some load should be placed on the power transformer to limit transients to 120 percent of the d-c voltage.

Tube Protection

Fault overloads, due to tube or circuit instabilities, may result in the following conditions:

- (a) liberation of gas in the tube;
- (b) gross damage to internal elements, e.g. melting of grid wires;
- (c) external arcing over electrodes, with damage to seals and possible puncture of envelope insulator.

A tube which becomes gassy often can be cleaned up successfully by patient reaging. The other conditions listed above are usually catastrophic.

The criteria for tube protection are the total energy which may be imparted to the tube, and the peak voltage which may appear across the electrodes. The total energy available depends on the *power source impedance*, including effect of transmission lines, and the *energy stored* in the transformer and filter components; on the *series resistance* in the circuit; and on the *duration of the discharge* or fault condition.

Primary power characteristics often are not known by the equipment designer, and the major energy-storage components usually are fixed by circuit performance requirements. Tube protection, then, is reduced to limiting surges by the *design of certain components, including in the circuit*

at least some dissipative elements, i.e. resistance, and to sensing and removing any incipient surge as quickly as possible. The foregoing uncertainties make it difficult to specify the minimum requirements for sufficient tube protection under a given set of circumstances.

Protective Devices and Circuitry

Heretofore, it has been customary to equip plate and grid circuits with overload relays adjusted to open the circuit breakers within one-tenth of a second. In many applications, particularly where the impedance of the primary power source is low or where there is appreciable stored energy, the devices referred to above offer inadequate protection.

For high reliability and freedom from gassing and catastrophic failures, the use of an electronic shorting device or "crowbar" is recommended. In this case a thyatron, ignitron, or other suitable gaseous conduction device is connected to short the rectifier output to ground within 50 microseconds in the event of a fault condition. The electronic crowbar functions to divert the fault energy from the protected tube until the relay and circuit breakers act. Where multiple tubes are used with a common power supply, this type of crowbar is certainly necessary. This type of high-speed removal of fault energy has been extremely effective in reducing break-in time, and the lower the power supply impedance, the more impressive is the effect.

In some cases adequate protection can be obtained by using a vacuum switch, (a) connected as above, or (b) as a circuit breaker, replacing the usual slower acting types. These devices can divert, or remove, the fault energy in the order of one-half cycle. A vacuum-switch circuit breaker can, of course, be used to advantage in combination with the high-speed electronic shorting device. *The latter arrangement probably gives the best over-all protection to the tube and other circuit components.*

In addition, some *series resistance* should be used in the output of the power supply to limit the surge current from the transformer. Preferably, resistors may be placed in series with each rectifier lead to provide equal protection with substantially less power dissipated during normal operation. The amount of resistance will vary with circuit conditions and the speed of the protective circuitry, but the following values can be given as a guide:

Maximum Power Output of Rectifier	120	250	500	1000 kW
Series Resistor	10	20	35	50 Ohms

The voltage ratings of these tubes are established so that normal operation will not cause arcs to develop across the tube envelope. Any external arcing, therefore, is an indication that the rated voltages have been exceeded. To lessen the chance of permanently damaging the tube, it is helpful to attach suitable *sphere gaps*, or rings, to the electrode terminals. If the sphere gaps are properly installed, the most probable breakdown path is between the gaps rather than over the tube envelope. The gap separation must be carefully adjusted for each application. The spacing from the tube envelope to the gaps or rings, in general, should be equal to or greater than the gap separation.

Maintenance

The anode cooling fins of the ML-6697A must be kept free from films of foreign materials, which will impair heat flow. To keep fins clean, it is suggested that ultrasonic cleaning or wire-brushing of the anode cooling surfaces be performed on a routine maintenance basis.

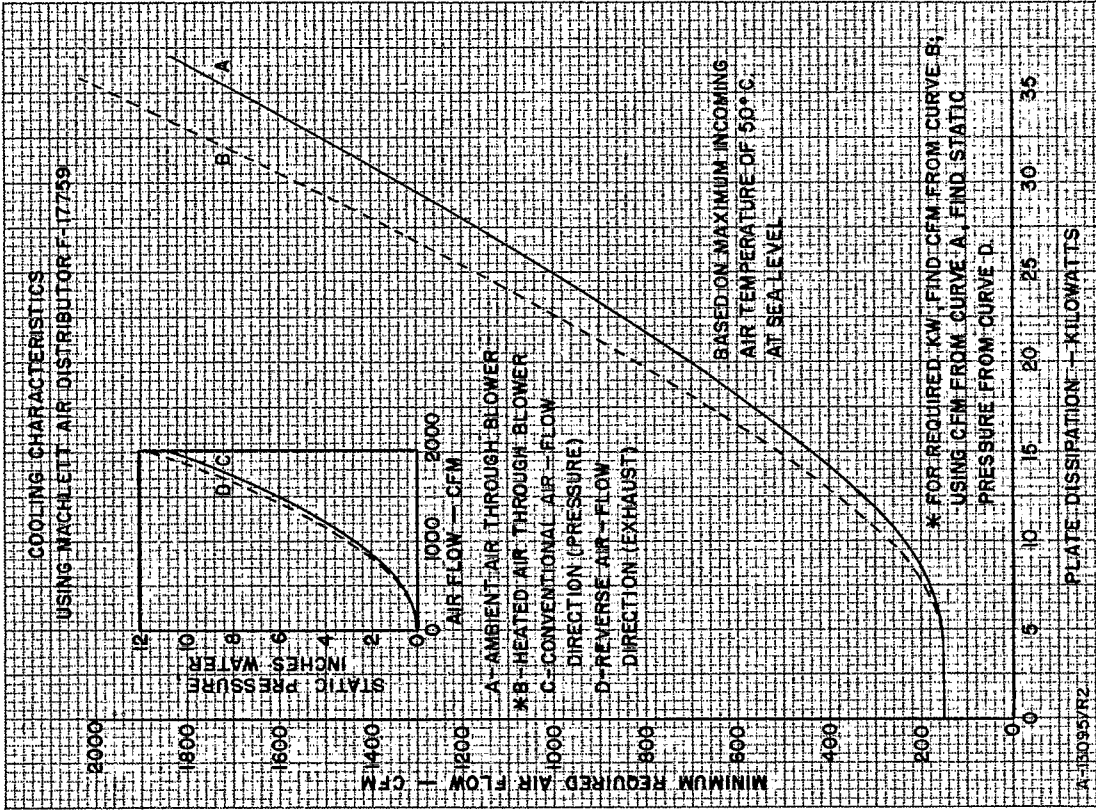

COOLING CHARACTERISTICS — ML-6697A

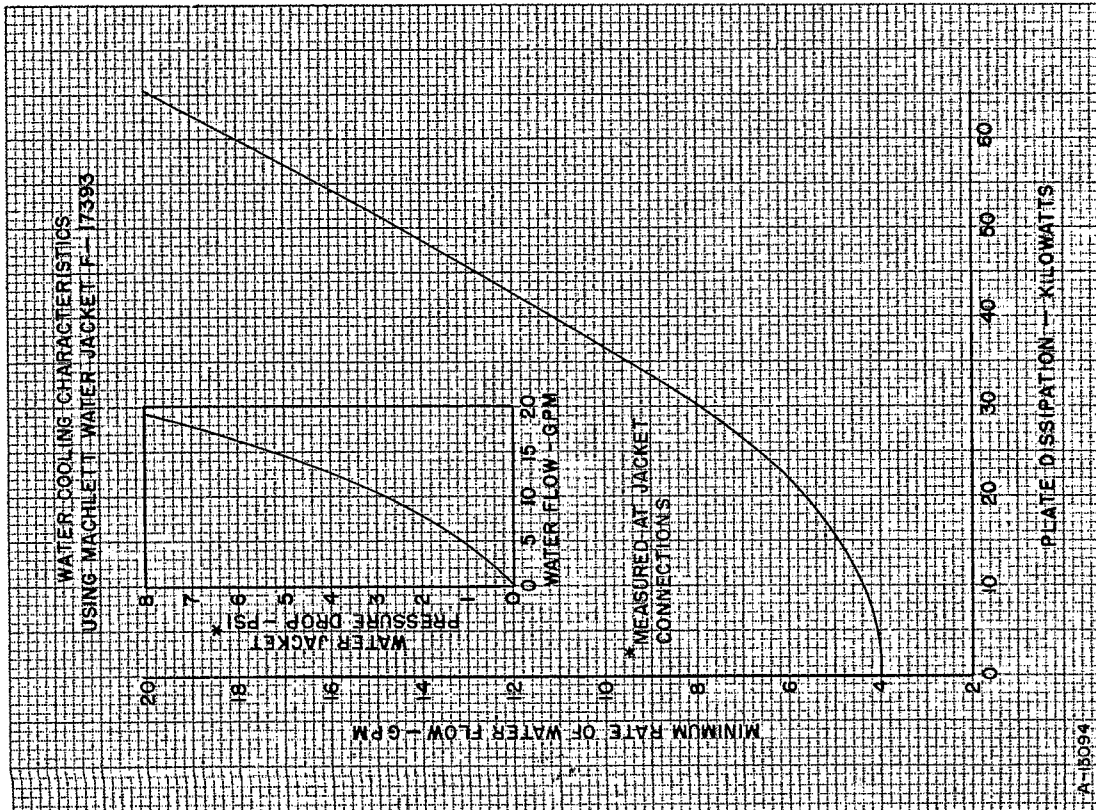

COOLING CHARACTERISTICS — ML-6696A

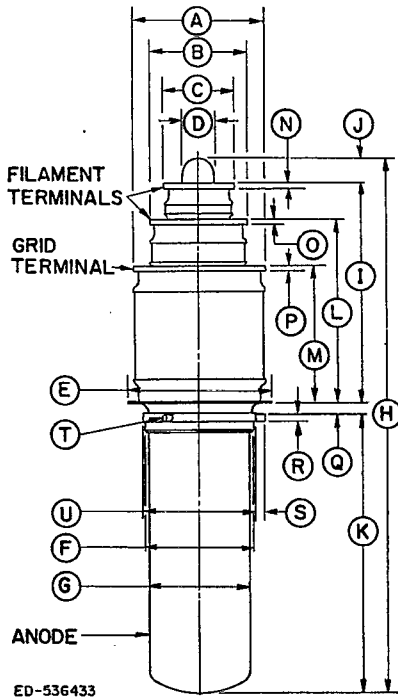

ML-6696A

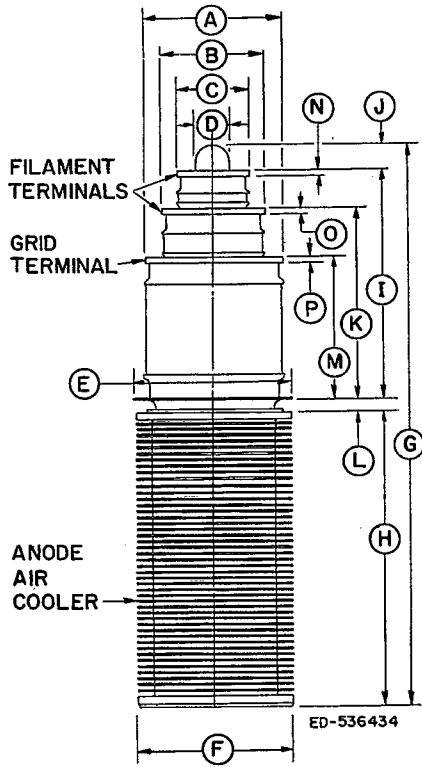

ML-6697A

DIMENSIONS FOR OUTLINE OF ML-6696A

Ref.	Inches			Notes
	Minimum	Nominal	Maximum	
A	4.619	4.650	4.681	
B	3.469	3.500	3.531	
C	2.469	2.500	2.531	
D	—	1.12	1.19	
E	—	—	5.25	
F	3.990	3.995	4.000	
G	3.485	3.500	3.515	
H	—	19.16	19.38	
I	7.75	7.88	8.00	
J	—	.94	1.00	
K	9.75	9.87	10.00	
L	6.50	6.62	6.75	
M	4.81	4.88	4.94	
N	.12	.18	—	
O	.12	.18	—	
P	.12	.18	—	
Q	.40	.44	.47	
R	.300	.310	.320	1
S	.28	.31	.35	1
T	—	120°	—	1
U	4.00	4.03	4.06	

NOTES:

1. Three bayonet pins for water jacket connection, diameter (R), length (S), nominally (T) degrees apart.

DIMENSIONS FOR OUTLINE OF ML-6697A

Ref.	Inches			Notes
	Minimum	Nominal	Maximum	
A	4.619	4.650	4.681	
B	3.469	3.500	3.531	
C	2.469	2.500	2.531	
D	—	1.12	1.19	
E	—	—	5.25	
F	5.219	5.250	5.281	
G	—	19.36	19.88	
H	10.00	10.12	10.25	
I	7.75	7.88	8.00	
J	—	.94	1.00	
K	6.50	6.62	6.75	
L	.31	.45	—	
M	4.81	4.88	4.94	
N	.12	.18	—	
O	.12	.18	—	
P	.12	.18	—	

RAYTHEON

THE MACHLETT LABORATORIES, INC.

A SUBSIDIARY OF RAYTHEON COMPANY