

8072 Power Tube

VHF Linear Amplifier Tube

- Coaxial-Electrode Structure
- Ceramic-Metal Seals
- Full Input to 500 MHz
- Conduction Cooled

The BURLE 8072 is a small, conduction cooled beam power tube designed for use as an RF power amplifier, oscillator, regulator, distributed amplifier, or linear RF power amplifier in mobile or fixed station equipment.

Because of its high power sensitivity and high efficiency, the 8072 can be operated with relatively low anode voltage to give large power output with small driving power.

In typical operation as a linear RF power amplifier in single sideband, suppressed carrier service, the 8072 is rated for a useful peak power output of 80 watts as measured with two tone modulation. As an anode-modulated RF power amplifier in Class C telephony, it can deliver up to 105 watts of useful output power in a grid drive circuit up to 50 MHz. As an RF power amplifier in Class C telegraphy or FM telephony, the 8072 can deliver up to 110 watts at 50 MHz, 105 watts at 175 MHz and up to 85 watts at 470 MHz.

The terminal arrangement of the 8072 facilitates use of the tube with tank circuits of either the coaxial or strip-line type. Effective isolation of the output circuit from the input circuit is provided at the higher frequencies by the low inductance ring terminal for grid No.2. Base pin terminals for grid No.2 are also available for operation at the lower frequencies. The tripod arrangement of both the cathode and the grid No.1 leads enhances electrical characteristics. The three cathode leads reduce the inductance path of RF ground and reduce the input admittance at high frequencies. The three grid No.1 leads to separate pins accommodate a split input circuit for distributed amplifier service.

This data sheet gives application information unique to the 8072. The directions and recommendations contained herein must be reviewed and followed to obtain optimum performance. Important additional information of a general nature, applicable to tubes of this type, is given in the following publications:

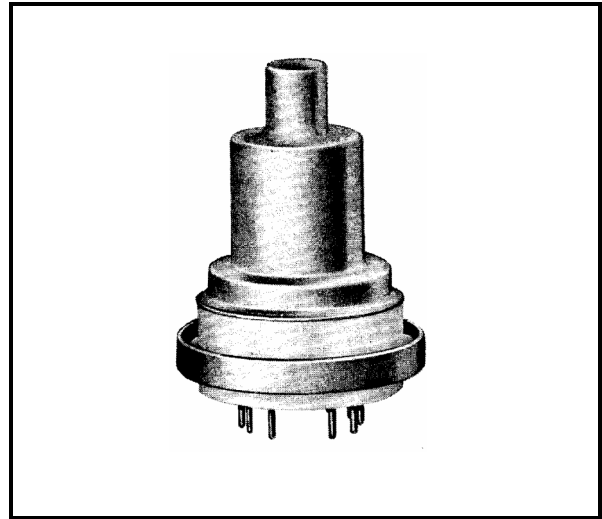

- TP-105 Application Guide to BURLE Power Tubes
- TP-1 17 Handling and Operating Considerations When Using BURLE Tetrodes
- TP-122 Screen Grid Current, Loading, and Bleeder Considerations

Close attention to these instructions will assure longer tube life, safer operation, less equipment downtime and fewer tube handling accidents.

For specific information or application assistance, contact your nearest BURLE Sales Representative or write Power Tube Marketing, BURLE INDUSTRIES, INC., 1000 New Holland Avenue, Lancaster, PA 17601-5688.

General Data

Electrical

Heater:			
Type		Unipotential Cathode	
Voltage	13.5+10%		v
Current at 13.5 volts	1.3		A
Minimum heating time	60		S
Mu Factor (Grid No.2 to grid No.1)	11		
Direct Interelectrode Capacitances:			
Grid No.1 to anode	.15	max	pF
Grid No.1 to cathode	16.3		pF
Anode to cathode	.01		pF
Grid No.1 to grid No.2	23.3		pF
Grid No.2 to anode	6.4		pF
Grid No.2 to cathode	2.7		pF
Cathode to heater	3.3		pF



General Data (Cont'd)

Mechanical		
Operating Attitude		Any
Maximum Length	57.4 mm (2.26 in)	
Seated Length	48.8 mm (1.92 in)	
Greatest Diameter	36.5 mm (1.436 in)	
Base	JEDEC No. E11-81	
Socket	No.124-31 1-100 or equivalent	
Bypass	No.124-1 13-018 or equivalent	
Weight		2.0 oz
Thermal		
Terminal Seal Temperature (All Terminals)	250 max.	°C
Anode Core Temperature	250 max.	°C

Anode-Modulated RF Power Amplifier - Class C

Telephony

Carrier conditions per tube for use with a maximum modulation factor of 1.0.

Maximum CCS Ratings, Absolute-Maximum Values

	up to 500 MHz	
DC Anode Voltage	1800	V
DC Grid-No.2 Voltage	400	v
DC Grid-No.1 Voltage	-100	V
DC Anode Current	250	mA
DC Grid-No.1 Current	100	mA
DC Grid-No.2 Input	5	W
Anode Dissipation	70	w

Typical CCS Operation

	In grid-drive circuit at 50 MHz	
DC Anode Voltage	500	700 V
DC Grid-No.2 Voltage	150	150 V
DC Grid-No. 1 Voltage	-20	-25 V
DC Anode Current	200	250 mA
DC Grid-No.2 Current	35	40 mA
DC Grid-No. 1 Current	20	35 mA
Driver Power Output (Approx.)	1.2	2 W
Output Circuit Efficiency (Approx.)	90	90 %
Useful Power Output (Approx.)	54	105 W

Maximum Circuit Values

Grid-No.1 Circuit Resistance Under Any Condition:	
With fixed bias	25,000 ohms
Grid-No.2 Circuit Impedance	10,000 ohms
Anode Circuit Impedance	See Note 5

Linear RF Power Amplifier

Single-Sideband Suppressed-Carrier Service

Peak envelope conditions for a signal having a minimum peak-to-average power ratio of 2.

Maximum CCS Ratings, Absolute-Maximum Values

	Up to 500 MHz	
DC Anode Voltage	2200	V
DC Grid-No.2 Voltage	400	V
DC Grid-No.1 Voltage	-100	V
DC Anode Current at Peak of Envelope	450	mA
DC Grid-No.1 Current	100	mA
Anode Dissipation	100	W
Grid-No.2 Dissipation	8	W
Peak Heater-Cathode Voltage:		
Heater negative with respect to cathode	150	V
Heater positive with respect to cathode	150	V

Typical CCS Operation with "Two-Tone Modulation"

	At 30 MHz	
DC Anode Voltage	700	V
DC Grid-No.2 Voltage	250	V
DC Grid-No.1 Voltage	-20	V
Zero-Signal DC Anode Current	100	mA
Effective RF Load Resistance	1420	ohms
DC Anode Current at Peak of Envelope	205	mA
Average DC Anode Current	150	mA
DC Grid-No.2 Current at Peak of Envelope	16	mA
Average DC Grid-No.2 Current	10	mA
Average DC Grid-No.1 Current'	1.0	mA
Peak-Envelope Driver Power Output ² (Approx.)	0.3	W
Output-Circuit Efficiency (Approx.)	95	%
Distortion Products Level: ³		
Third order	30	dB
Fifth order	35	dB
Useful Power Output (Approx.):		
Average	40	W
Peak envelope	80	W

Maximum Circuit Values

Grid-No.1 Circuit Resistance Under Any Condition:	
With fixed bias	25,000 ohms
With fixed bias (In Class AB, operation)	100,000 ohms
With cathode bias	Not Recommended
Grid-No.2 Circuit Impedance	10,000 ohms
Anode Circuit Impedance	See Note 4

RF Power Amplifier & Oscillator - Class C Telegraphy and RF

Power Amplifier - Class C FM Telephony

Maximum CCS Ratings, Absolute-Maximum Values

	Up to 500 MHz	
DC Anode Voltage	2200	V
DC Grid-No.2 Voltage	400	V
DC Grid-No. 1 Voltage	-100	V
DC Anode Current	300	mA
DC Grid-No.1 Current	100	mA
DC Grid-No.2 Dissipation	8	W
Anode Dissipation	100	W
Peak Heater-Cathode Voltage:		
Heater negative with respect to cathode	150	V
Heater positive with respect to cathode	150	V

Typical CCS Operation

	In grid-drive circuit at 50 MHz	
DC Anode Voltage	500	700 V
DC Grid-No.2 Voltage	160	175 V
DC Grid-No.1 Voltage	-10	-10 V
DC Anode Current	300	300 mA
DC Grid-No.2 Current	25	2.5 mA
DC Grid-No.1 Current	50	5.0 mA
Driver Power Output (Approx.) ²	1.2	1.2 W
Useful Power Output	85	110 W

In grid-drive circuit at 175 MHz

DC Anode Voltage	500	700 V
DC Grid-No.2 Voltage	200	200 V
DC Grid-No.1 Voltage	-30	-30 V
DC Anode Current	300	300 mA
DC Grid-No.2 Current	30	20 mA
DC Grid-No.1 Current	40	40 mA
Driver Power Output (Approx.) ²	3	3 W
Useful Power Output	70	105 W

In grid-drive circuit at 470 MHz

DC Anode Voltage	700	V
DC Grid-No.2 Voltage	200	V
DC Grid-No.1 Voltage	-30	V
DC Anode Current	300	mA
DC Grid-No.2 Current	10	mA
DC Grid-No.1 Current	20	mA
Driver Power Output (Approx.) ²	5	W
Useful Power Output	85	w

Maximum Circuit Values

Grid-No.1 Circuit Resistance Under Any Condition:		
With fixed bias	25,000	ohms
Grid-No.2 Circuit Impedance	10,000	ohms
Anode Circuit Impedance	See	Note 5

Characteristics Range Values

	Min.	Max.	
Heater Current ⁵	1.15	1.45	A
Direct Interelectrode Capacitances:			
Grid No.1 to anode	-	0.15	pF
Grid No.1 to cathode	14.6	18.0	pF
Anode to cathode	004	.016	pF
Grid No.1 to grid No.2	20.0	26.5	pF
Grid No.2 to anode	5.7	7.1	pF
Grid No.2 to cathode	2.1	3.3	pF
Cathode to heater	2.5	4.1	pF
Grid-No.1 Voltage ⁶	-8	-19	V
Reverse Grid-No.1 Current ⁶	-	-25	mA
Grid-No.2 Current ⁶	-5	+6	mA
Peak Emission ⁷	13	-	A
Interelectrode Leakage Resistance ⁸	50	-	M o h m s
Useful Power Output ⁹	75	-	W
Cutoff Grid-No.1 Voltage ¹⁰	-	-47	V

- This value represents the approximate grid-No.1 current obtained due to initial electron velocities and contact-potential effects when grid-No.1 is driven to zero volts at maximum signal.
- Driver power output represents circuit losses and is the actual power measured at input to grid-No.1 circuit. The actual power required depends on the operating frequency and the circuit used. The tube driving power is approximately zero watts.
- Referenced to either of the two tones, and without the use of feedback to enhance linearity.
- The tube should see an effective anode supply impedance which limits the peak current through the tube under surge conditions to 15 amperes.
- With 13.5 volts AC or DC on heater.
- With DC anode voltage of 700 volts, DC grid-No.2 voltage of 250 volts, and DC grid-No.1 voltage adjusted to give a DC anode current of 185 mA. $E_f = 13.5$ V.
- For conditions with grid No.1, grid No.2, and anode tied together; and pulse voltage source connected between anode and cathode. Pulse duration is 2.0 maximum microseconds and duty factor is 0.0002 maximum. The voltage-pulse amplitude is 200 volts peak. After 1 minute at this value, the current-pulse amplitude will not be less than the value specified. $E_f = 13.5$ V.

- Under conditions with tube at 20 to 30 °C for at least 30 minutes without any voltages applied to the tube, The resistance between any two electrodes is measured with a 200-volt Megger-type ohmmeter, or equivalent, having an internal impedance of 1.0 megohm.
- In a CW grid-driven, conduction-cooled amplifier circuit at 470 MHz and for conditions: DC anode voltage of 700 volts, grid-No. 1 voltage of -28 to -32 volts, driven power output of 5 watts, and grid-No.2 voltage varied to obtain an anode current of 300 mA. $E_f = 12.5$ V.
- With DC anode voltage of 2000 volts, DC grid-No.2 voltage of 250 volts, and DC grid-No.1 voltage varied to obtain an anode current of 5 mA. $E_f = 13.5$ V.

Safety Precautions

Protection circuits serve a threefold purpose: safety of personnel, protection of the tube in the event of abnormal circuit operation, and protection of the tube circuits in the event of abnormal tube operation.

Power tubes require mechanical protective devices such as interlocks, relays, and circuit breakers. Circuit breakers alone may not provide adequate protection in certain power tube circuits when the power-supply filter, modulator, or pulse-forming network stores much energy. Additional protection may be achieved by the use of high-speed electronic circuits to bypass the fault current until mechanical circuit breakers are opened. These circuits may employ a controlled gas tube, such as a thyratron or ignitron, depending on the amount of energy to be handled.

Warning - Personal Safety Hazards

Electrical Shock - Operating voltages applied to this device present a shock hazard.

Great care should be taken during the adjustment of circuits. The tube and its associated apparatus, especially all parts which may be at high potential above ground, should be housed in a protective enclosure. The protective housing should be designed with interlocks so that personnel cannot possibly come in contact with any high-potential point in the electrical system. The interlock devices should function to break the primary circuit of the high-voltage supplies and discharge high-voltage capacitors when any gate or door on the protective housing is opened, and should prevent the closing of this primary circuit until the door is again locked.

Mechanical Considerations Mounting

The BURLE 8072 may be operated at any altitude and sockets are available for its installation.

Socket: Erie No.9813-000^a or equivalent;
Johnson No.124-311-100^b

Grid No.2 By-pass Capacitor: Erie No.9812-000^a
or equivalent;
Johnson No.1 24-0113-001^b

Conduction Cooling

The absolute maximum temperature of the terminal seals and the anode core is 250 °C. This value may not be exceeded under any circumstances. It is recommended that the terminal seals and anode core be maintained at a temperature well below the maximum limit in order to extend the tube life to a maximum.

^a Erie Specialty Products, 645 W. 11th St., Erie, PA 16512.

^b E.F. Johnson Co., 299 Johnson Ave., Waseca, MN 56093.

The anode terminal must be thermally coupled to a constant temperature heat sink to assure that it does not approach the maximum allowable temperature. The other terminal seals may also require coupling to the heat sink to limit their respective maximum temperatures.

The maximum anode dissipation is limited by the maximum anode core temperature and the cooling system to maintain tube operation below the maximum temperature values. Simple cooling techniques can limit the maximum anode dissipation to 100 watts. More sophisticated techniques may permit maximum anode dissipation as high as 300 watts and still maintain the temperature within its maximum limit.

For measuring temperature, a small thermocouple may be used in cases where the hot junction can make good heat contact with the metal surface being measured. Use great caution to assure high voltage isolation. Temperature may also be measured using "Tempilaq", a temperature-sensitive paint manufactured by Tempil Division, Air Liquide America Corporation, 2901 Hamilton Boulevard, South Plainfield, NJ 07080. Website: <http://www.tempil.com>. Tempilaq is available in steps of 20 to 30 °C. Use the paint applied sparingly, in small dabs, to the surface. If the specified temperature of the paint is exceeded, the paint will melt and change appearance from dull to shiny.

Electrical Considerations Heaters

The heater voltage must be measured at the tube terminals. The specified voltage is 13.5 ± 1.35 volts. For accurate data the AC heater voltage should be measured using an RMS type meter such as an iron vane or thermocouple type meter. DC voltage should be measured with a high impedance meter.

For heaters such as are used in this tube, it is recommended that the current be monitored, since very small changes in resistance can produce misleading changes in voltage. For maximum life, the heater power should be regulated at the lowest value that will give stable performance. For those applications where hum is a critical consideration, DC heaters or hum bucking circuits are recommended.

The heater is affected by back bombardment as the frequency of operation is increased. For operation at frequencies up to 300 MHz the recommended heater voltage is 13.5 volts. From 300 to 400 MHz the heater voltage should be 13.0 volts. Above 400 MHz the heater voltage should be reduced to 12.5 volts.

Sequence for Applying Voltage

In order to assure optimum life and avoid catastrophic failures it is important to apply the operating voltages in a prescribed sequence allowing sufficient time to permit equalization of characteristics before proceeding to the next step.

The sequence for applying voltages is as follows:

- Heater
- Bias
- Anode
- Screen
- RF Drive

The amplification factor "Mu" was measured under the following conditions:

- Anode voltage = 250 V
- Grid-No.2 voltage = 200 V
- Anode current = 1.2 A

The interelectrode capacitances were analyzed with a special shield adapter which facilitated the measurement of the internal capacitance of the tube and discounted the external stray and circuit capacitances.

The maximum voltage ratings for this tube must be modified for operation at altitudes higher than sea-level and for temperatures in excess of 200 °C in accordance with the curves of **Figure 1**.

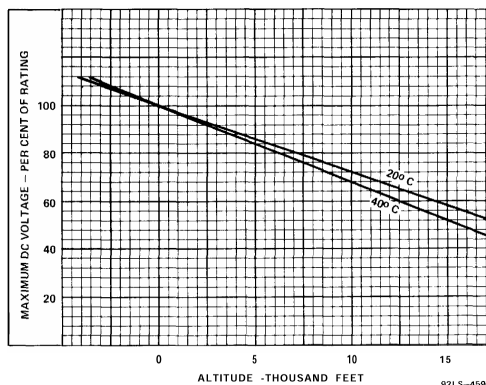

Figure 1 - Maximum DC Voltage with Respect to Altitude and Temperature

The maximum fault energy that can be dissipated within the tube is five joules. Therefore the energy available for a high voltage arc or fault must be limited to this value by means of current limiting resistors or fault protection circuitry.

The anode voltage supply is usually obtained from rectifiers provided with suitable filter circuits, although batteries or local DC generators are sometimes used, especially in portable and mobile equipment.

A time-delay relay should be provided in the anode-supply circuit to delay application of anode voltage until the filament or heater has reached normal operating temperature.

An interlocking relay system should be provided to prevent application of anode voltage prior to the application of sufficient bias voltage otherwise, with insufficient bias, the resultant high anode current may cause excessive anode dissipation with consequent damage to the tube. RE-load shorts or other causes of high output VSWR may also cause high dissipations, excessive voltage gradients, or insulator flash-overs. The VSWR should be monitored and the detected signal used to actuate the interlock system to remove the anode voltage in less than 10 milliseconds after the fault occurs.

Anode Voltage Supply

In beam power tubes with closely spaced electrodes, extremely high-voltage gradients occur even with moderate tube operating voltages. Consequently, momentary fault currents may cause catastrophic failure unless protection is provided. A series impedance in the anode lead is recommended. A resultant anode impedance, which will provide an anode-voltage-supply regulation of no better than 10 percent is usually sufficient.

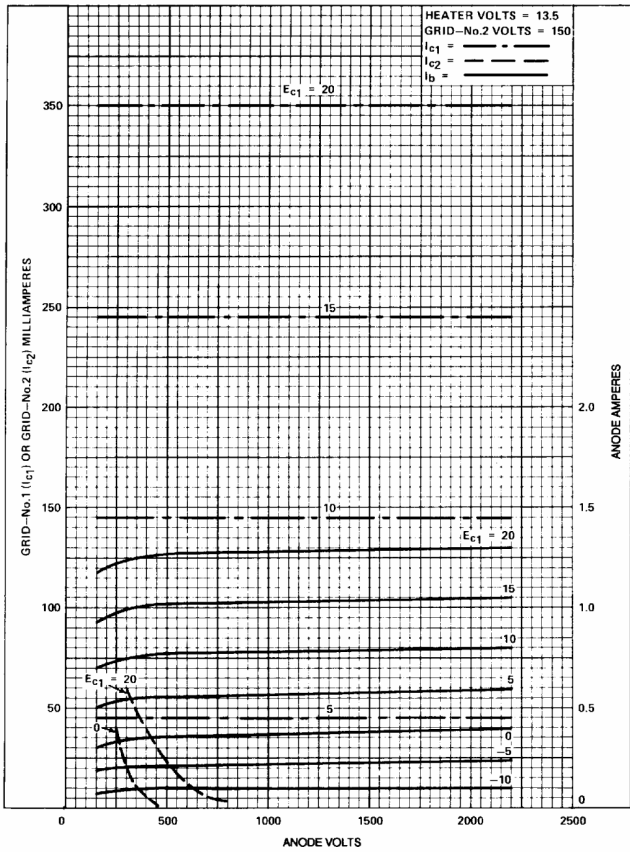

Figure 2 - Typical Characteristics

A fault-current limiting resistor of no less than 15 ohms must be used between the output filter capacitance and the tube plate. The plate supply output filter may be no greater than 10 uF.

Grid No.2 Voltage Supply

Grid-No.2 voltage for a beam power tube, may be obtained from a separate DC power supply or from the anode voltage supply for the tube. In the latter case, the required voltage may be obtained either from a voltage divider or through a series resistor.

The grid No.2 must be protected by a time-delay and interlocking relay similar to the anode-voltage-supply protection described in **Anode Voltage Supply**. The anode voltage should be applied simultaneously with or before the grid-No.2 voltage; otherwise, with voltage on grid No.2 only, grid-No.2 current may be large enough to cause excessive grid-No.2 dissipation. If the grid-No.2 voltage is obtained from the anode voltage supply, these precautions will have been accomplished.

Grid-No.2 current is composed of a positive-current component, the principal contributor to grid-No.2 dissipation, and of negative-current components resulting from primary- and secondary-emission phenomena. The net result of these component currents is read on a meter in the grid-No.2 circuit. Hence, grid-No.2 dissipation can not be accurately determined. Operation similar to conditions given under **Typical Operation** in the published data will minimize the possibility of exceeding maximum dissipation.

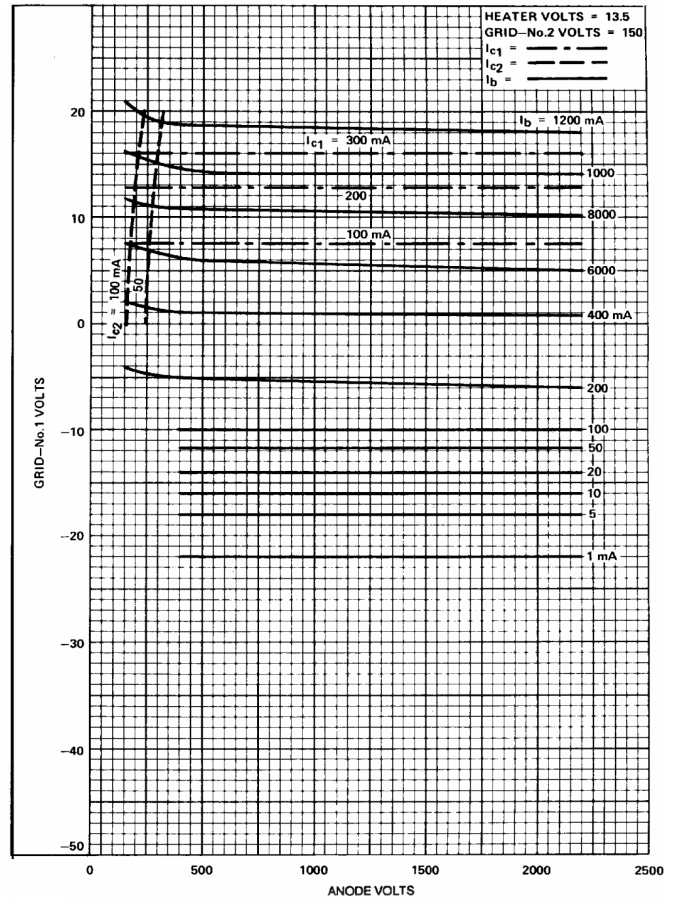

Figure 3 - Constant Current Characteristics

In tubes with precision-aligned grids, such as CERMOLUX® tubes, the grid-No.2 circuit must be capable of maintaining the proper grid-No.2 voltage in the presence of moderate negative DC current as well as normal values of positive current. Complete protection can be achieved by the use of a well-regulated power supply, a grid-No.2-to-ground impedance that is low enough to prevent gradual build-up of grid-No.2 voltage and/or catastrophic build-up (runaway) under negative-current conditions, and a current-overload relay to protect the grid No.2 against positive or negative currents on the order of one-tenth the required anode current.

A fault-current limiting resistor of no less than 320 ohms must be used between the grid No.2 output filter capacitance and grid No.2. The supply output filter capacitance may be no large than 80 uF.

For additional information on grid No.2 operation, see the BURLE Application Note TP-122, "Screen Grid Current, Loading, and Bleeder Considerations."

Grid-No.1 Voltage Supply

Grid-No.1 voltage or bias for a power tube may be obtained from a separate power supply or a resistor in the grid or cathode circuit. In general, the method recommended for a particular application is given below for the class of service in which the power tube is to be used.

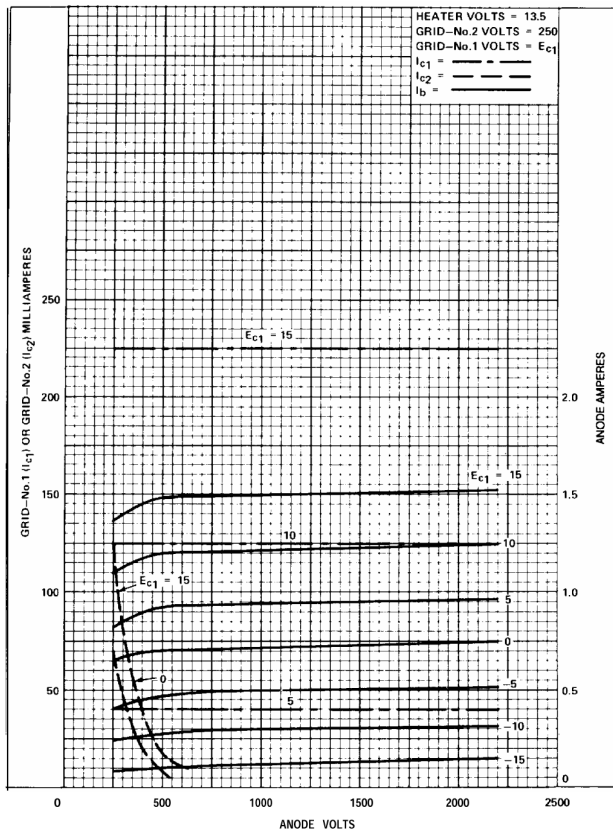

Figure 4 - Typical Characteristics

The grid-No.1 bias circuit should preferably be adjustable to permit small variations of grid-No.1 voltage. This bias adjustment will permit setting the desired anode current, and it will minimize variations in tube performance. Sufficient fixed bias or cathode resistor bias should be provided to protect the tube in the event that the drive signal is lost.

The design of the bias-voltage supply should include an instantaneous over-current relay. The regulation of the supply should be such that no damage to the tube or supply will result from an accidental short at the tube connection or from an internal tube fault.

The RE-power-input transmission line should be provided with VSWR protection to remove drive power as well as anode (and grid-No.2) voltage within 10 milliseconds in the event of abnormal changes in input VSWR during operation.

A fault-current limiting resistor of no less than 20 ohms is to be used between the bias supply output filter capacitance and the tube grid No.1. The bias supply output filter capacitance may be no greater than 150 uF.

Modes of Operation Linear RF Power Amplifiers

The classes of operation suitable for linear RE power amplifiers include: Class A, Class AB₁, Class AB₂, Class B with bias, and

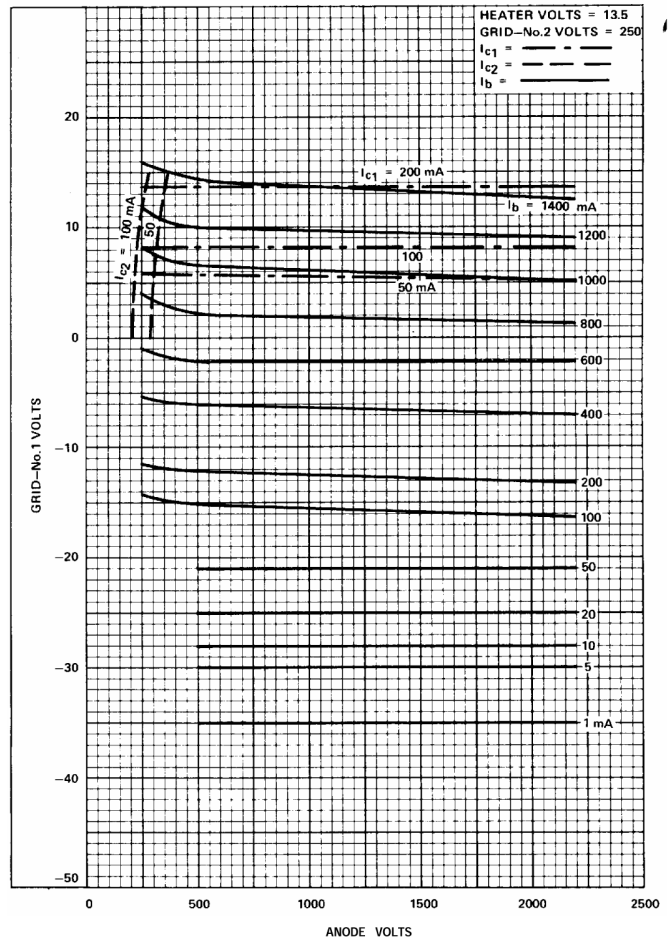

Figure 5 - Constant Current Characteristics

Class B with zero bias. Class A operation is the most nearly linear, but it is also the least efficient. Application is generally limited to low-power-level amplification. Class AB₁ produces the best compromise for linearity, efficiency, and gain. Class AB₁ or Class B operation provides higher output for applications where sufficient driving power is available to permit some "swamping" and where linearity requirements are less stringent. Class B zero-bias operation with suitable high mu triodes may be used when adequate driving power is available.

In general, grid-No.2 voltage should be obtained preferably from a separate, well-regulated source. In circuits where the grid-No.1 current is drawn, a separate, well-regulated source is also required.

Single Sideband, Suppressed Carrier Service

Single-sideband, suppressed-carrier operation is a form of linear amplifier service in which only one sideband is transmitted, and the carrier is suppressed. Maximum ratings on a particular type in this service are given in the data for peak envelope conditions for a signal having a minimum peak-to-average power ratio of two unless otherwise specified.

The values of Distortion Products Level given under **Typical Operation** in the data are referenced to either of the two tones for "two-tone" modulation and are without the use of feedback to enhance linearity.

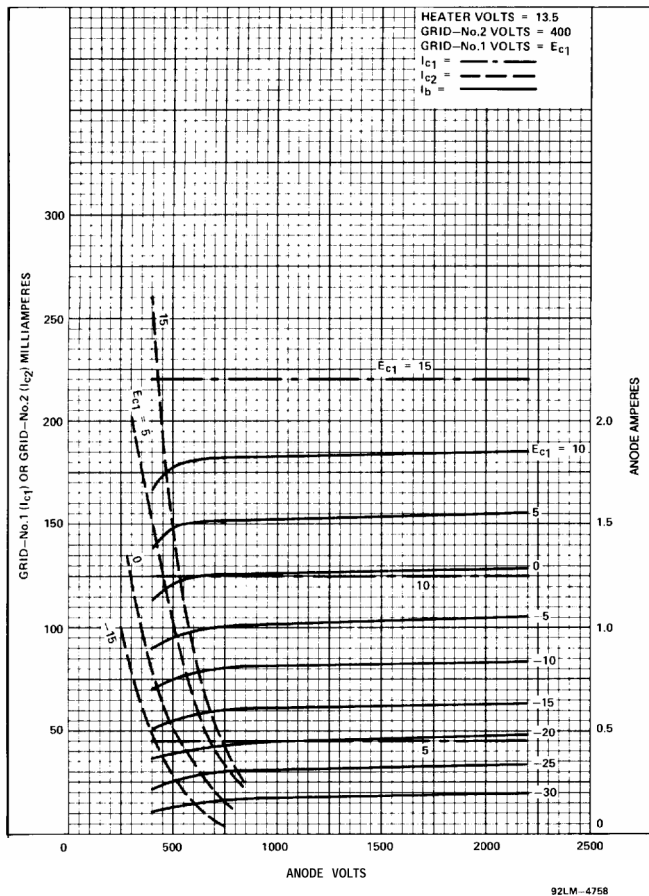

Figure 6- Constant Current Characteristics

A parasitic anode suppressor is recommended for use in SSB circuitry.

Class C Anode-Modulated RF Power Amplifiers

In anode-modulated Class C amplifier service, the tube can be modulated up to 100 percent. The grid-No.2 voltage must be modulated simultaneously with the anode voltage so that the ratio of grid-No.2 voltage to anode voltage remains constant.

Grid-No.2 voltage should be obtained preferably from a separate source modulated from a separate winding on the modulation transformer. In less critical circuits, grid-No.2 voltage may sometimes be obtained from the modulated anode supply through a series resistor or by connecting grid No.2 through an audio-frequency choke of suitable impedance for low audio frequencies to the fixed grid-No.2 supply voltage. The supply end of the choke should be well-bypassed to ground.

Bias voltage may be obtained from a grid-No.1 resistor, but preferably is obtained from a combination of grid-No.1 resistor with either fixed supply or cathode resistor to protect the tube in the event the drive signal is lost.

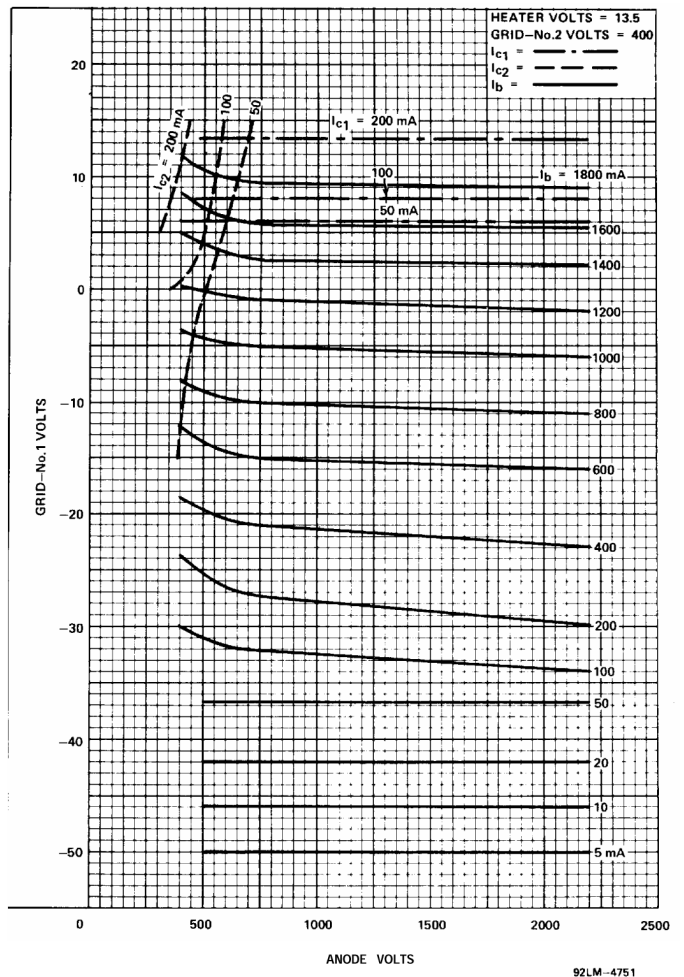

Figure 7 - Constant Current Characteristics

In cathode-drive, anode-modulated, Class C RF power amplifier service, the tube can be modulated up to 100 percent if the RF driver stage is simultaneously modulated equally. Care should be taken to insure that the driver-modulation and amplifier-modulation voltages are exactly in phase.

Class C CW Power Amplifiers

In Class C RE telegraphy or EM service, the tube may generally be supplied with bias by any convenient method: from fixed supply, by grid-No.1 resistor, by cathode resistor, or by combination methods. However, when the tube is used in the final amplifier or a preceding stage of a transmitter designed for break-in operation and oscillator keying, an amount of fixed bias must be used to limit the anode current and, therefore, the anode dissipation, to a safe value. Some fixed bias is preferred in any event to protect the tube in case the drive signal is lost.

Grid-No.2 voltage should be obtained preferably from a separate source. It can also be obtained from the anode supply voltage with a voltage divider, or through a series resistor. A series grid-No.2 resistor should be used only when the tube is used in a circuit which is not keyed.

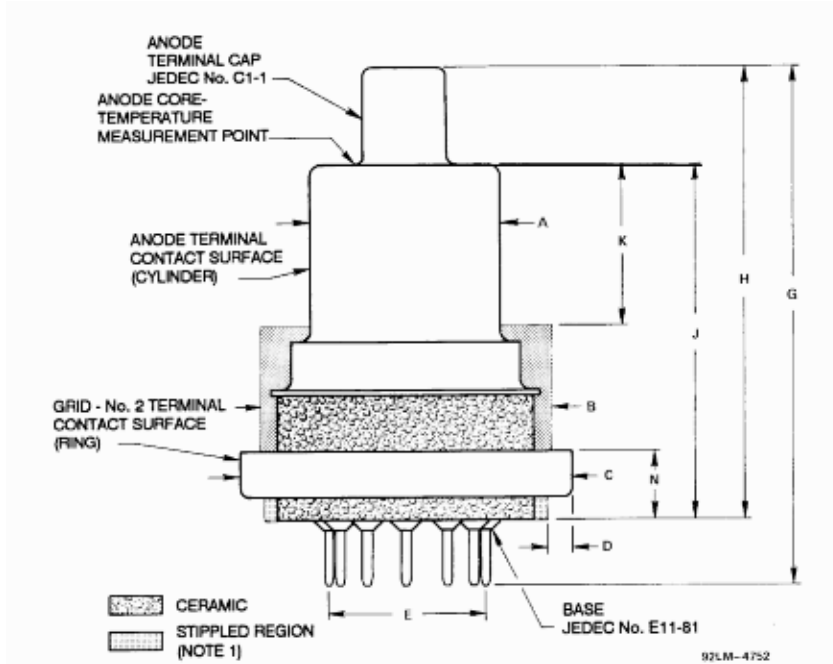

Tabulated Dimensions

Dim.	Millimeters	Inches	Notes
A Dia.	20.47 ± .13	(0.806 ± .005)	2,3
B Dia.	31.75 max.	(1.250 max.)	1
C Dia.	36.22 ± .25	(1.426 ± .010)	2,3,4
D	2.03 min.	(0.080 min.)	
E Dia.	17.44 ref.	(0.687 ref.)	2,3
G	57.40 max.	(2.26 max.)	
H	48.8 ± 1.6	(1.920 ± .065)	
J	38.6 ± 1.0	(1.515 ± .045)	
K	17.78 min.	(0.700 min.)	
N	7.62 ± .51	(0.300 ± .020)	

Note 1 - Keep all stippled regions clear. Do not allow contacts or circuit components to protrude into these annular volumes.

Note 2 - The diameters of the anode terminal contact surface, grid No.2 terminal contact surface, and pin circle to be concentric within the following values of maximum full indicator reading:

Anode Terminal Contact Surface to Grid-No.2 Terminal Contact Surface	0.030 in.
Anode Terminal Contact Surface to Pin Circle	0.040 in.
Grid-No.2 Terminal Contact Surface to Pin Circuit	0.030 in.

Note 3 - The full indicator reading is the maximum deviation in radial position of a surface when the tube is completely rotated about the center of the reference surface. It is a measure of the total effect of run-out and ellipticity.

Note 4 - Terminal is uniform dimension for 3.8mm (0.150") minimum from the edge of the terminal.

Note 5 - Protection for vacuum tip off seal. Make no mechanical

Figure 8- Dimensional Outline

- Cap: Anode Terminal Connection
- Cylinder: Anode Terminal Contact Surface
(To contact to conduction-cooling system)
- Ring: Grid-No.2 Terminal Contact Surface
(For use at higher frequencies)

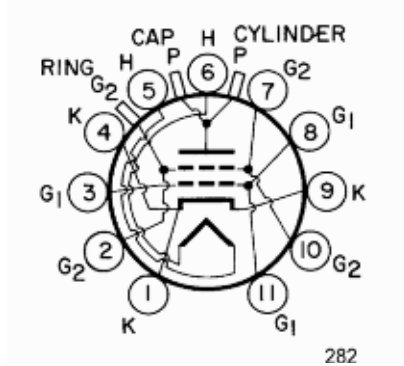

Figure 9 - Basing Diagram, Bottom View